

## PNP Silicon Epitaxial Planar Transistor

**B772**

### FEATURES

- Low speed switching.
- Low saturation voltage.
- Excellent  $h_{FE}$  linearity and high  $h_{FE}$ .
- Complementary: D882.

**HF**

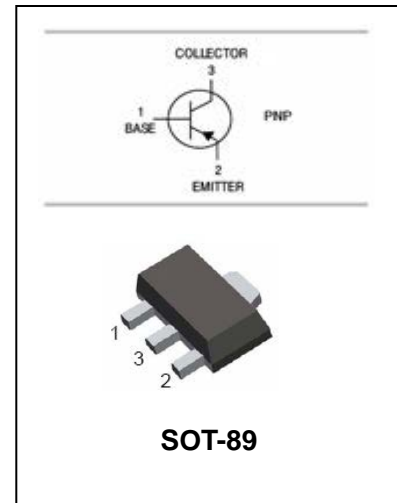

### APPLICATIONS

- Audio frequency power amplifier.

### ORDERING INFORMATION

Type No.	Marking	Package Code
B772	B772	SOT-89

### MAXIMUM RATING @ Ta=25°C unless otherwise specified

Symbol	Parameter	Value	Units
$V_{CBO}$	Collector-Base Voltage	-40	V
$V_{CEO}$	Collector-Emitter Voltage	-30	V
$V_{EBO}$	Emitter-Base Voltage	-5	V
$I_C$	Collector Current -Continuous	-3	A
$P_C$	Collector Dissipation	500	mW
$R_{\theta JA}$	Thermal Resistance Junction to Ambient Air	250	°C/W
$T_j, T_{stg}$	Junction and Storage Temperature	-55 to +150	°C

## PNP Silicon Epitaxial Planar Transistor

## B772

### ELECTRICAL CHARACTERISTICS @ Ta=25°C unless otherwise specified

Parameter	Symbol	Test conditions	MIN	TYP	MAX	UNIT
Collector-base breakdown voltage	$V_{(BR)CBO}$	$I_C=-100\mu A, I_E=0$	-40			V
Collector-emitter breakdown voltage	$V_{(BR)CEO}$	$I_C=-10mA, I_B=0$	-30			V
Emitter-base breakdown voltage	$V_{(BR)EBO}$	$I_E=-100\mu A, I_C=0$	-6			V
Collector cut-off current	$I_{CBO}$	$V_{CB}=-40V, I_B=0$			-1	$\mu A$
Collector cut-off current	$I_{CEO}$	$V_{CB}=-30V, I_E=0$			-1	$\mu A$
Emitter cut-off current	$I_{EBO}$	$V_{EB}=-6V, I_C=0$			-1	$\mu A$
DC current gain	$h_{FE}$	$V_{CE}=-2V, I_C=-1A$	60	160	400	
		$V_{CE}=-2V, I_C=-20mA$	30	220		
Collector-emitter saturation voltage	$V_{CE(sat)}$	$I_C=-2A, I_B=-0.2A$		-0.3	-0.5	V
Base-emitter saturation voltage	$V_{BE(sat)}$	$I_C=-2A, I_B=-0.2A$		-1.0	-2.0	V
Transition frequency	$f_T$	$V_{CE}=-5V, I_C=-0.1A$		80		MHz
Collector output capacitance	$C_{ob}$	$V_{CB}=-10V, I_E=0, f=1MHz$		55		pF

### CLASSIFICATION OF $h_{FE}$

Rank	R	O	Y	G
Range	60-120	100-200	160-320	200-400

PNP Silicon Epitaxial Planar Transistor

**B772**

TYPICAL CHARACTERISTICS @  $T_a=25^\circ\text{C}$  unless otherwise specified

STATIC CHARACTERISTIC

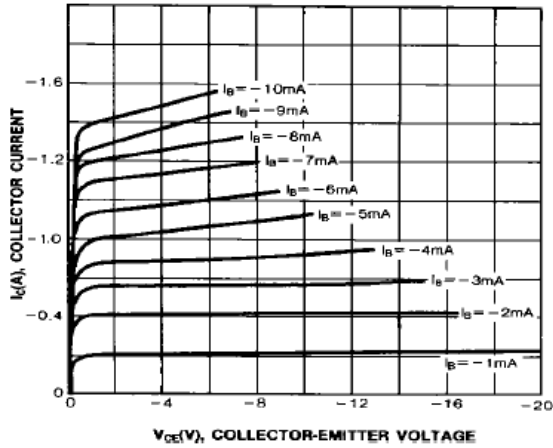

DC CURRENT GAIN

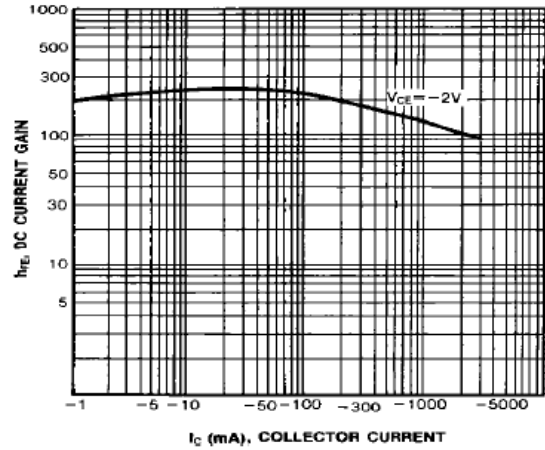

BASE-EMITTER SATURATION VOLTAGE  
COLLECTOR-EMITTER SATURATION VOLTAGE

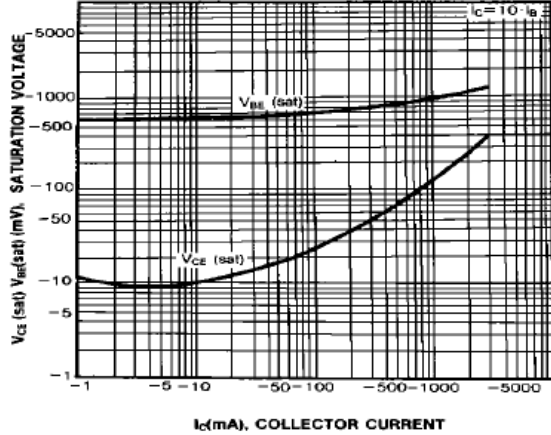

COLLECTOR OUTPUT CAPACITANCE

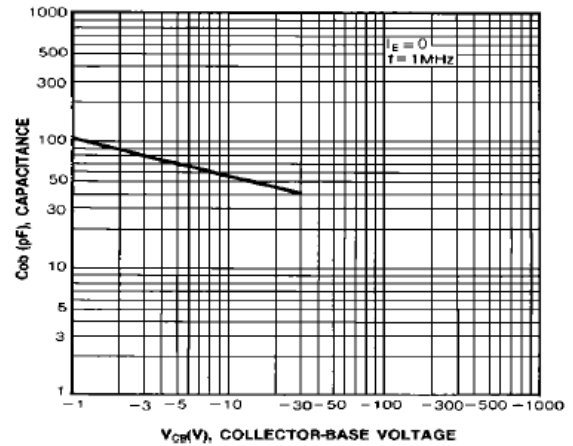

CURRENT GAIN-BANDWIDTH PRODUCT

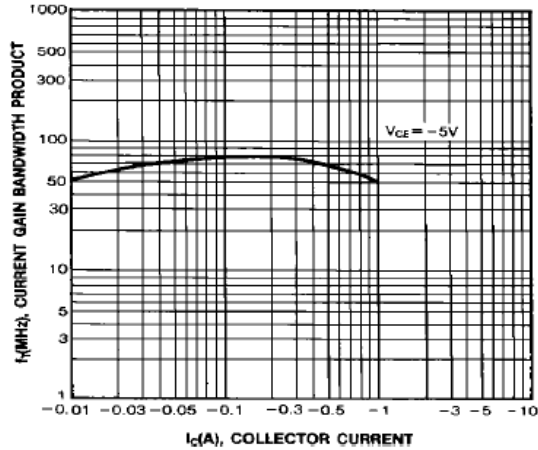

SAFE OPERATING AREA

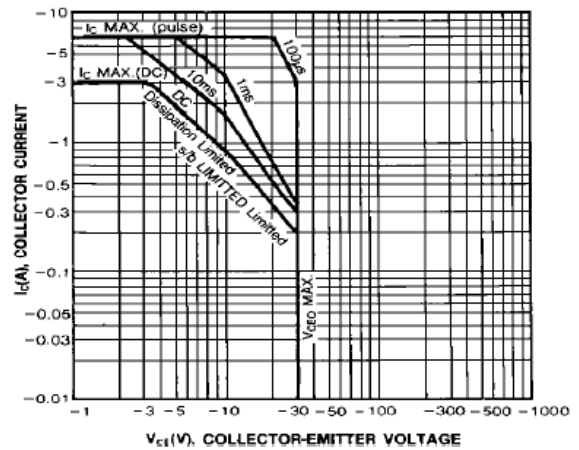

## PNP Silicon Epitaxial Planar Transistor

**B772**

### PACKAGE OUTLINE

Plastic surface mounted package

SOT-89

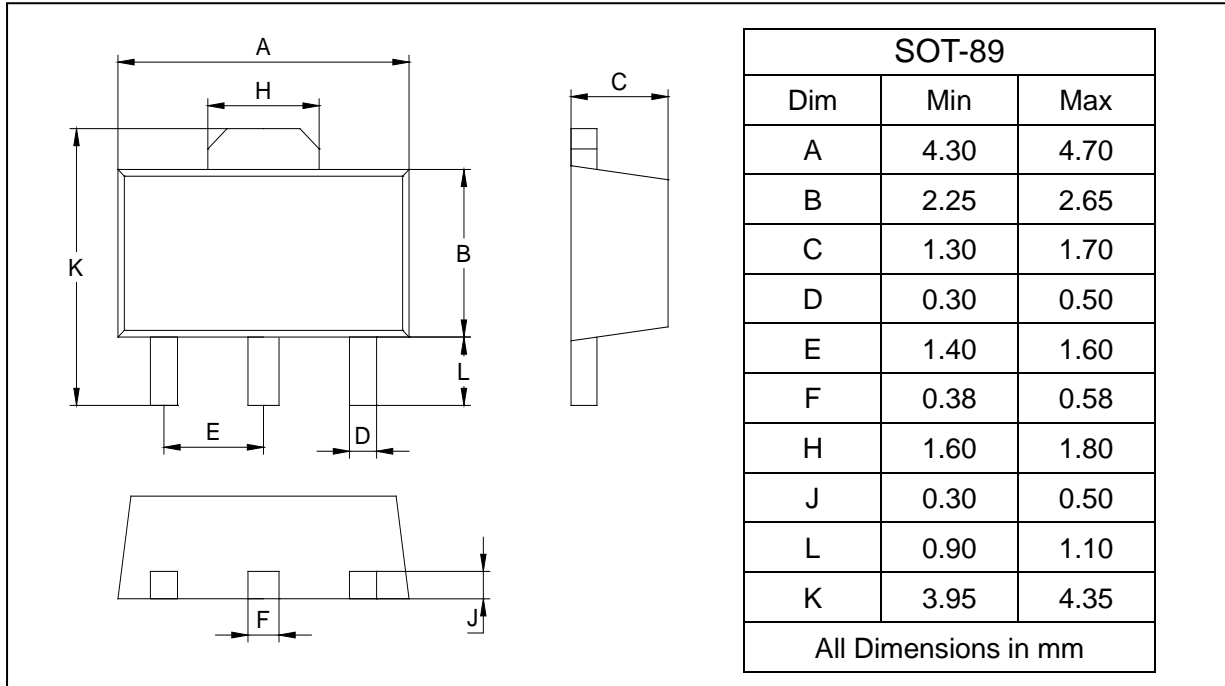

### SOLDERING FOOTPRINT

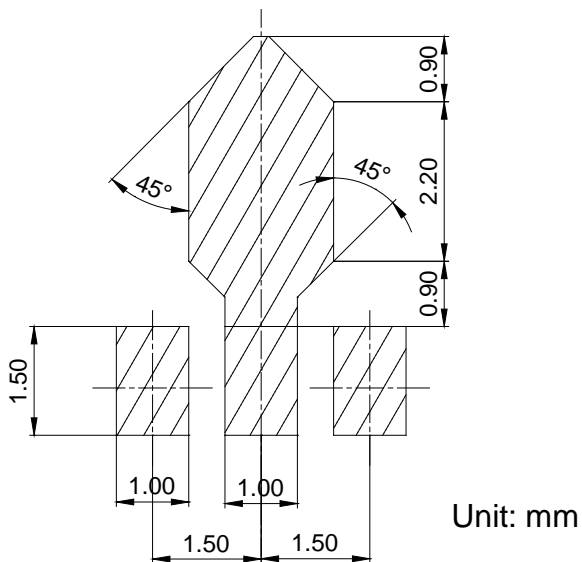

### PACKAGE INFORMATION

Device	Package	Shipping
B772	SOT-89	1000 pcs / Tape & Reel