

SMT-Type Zener Diode

BZT52C2V0-BZT52C75

FEATURES

- Large selection of zener voltages: 2.0V ~ 75V
- Tight voltage tolerance: $\pm 5\%$ for C-series
- Ultra low-profile package well suited for automated assembly
- MSL Class 1 compatible

HF

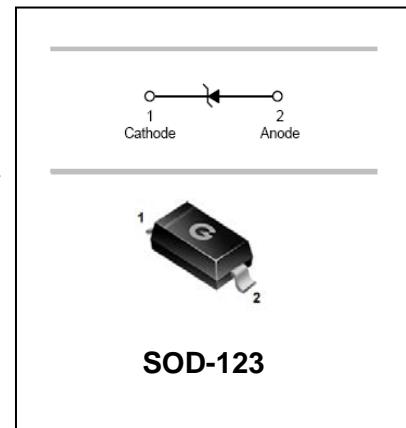

APPLICATIONS

- General voltage regulation
- Mobile & handheld systems

ORDERING INFORMATION

Part Number	Marking	Package
BZT52C2V0 - BZT52C75	See Electrical Characteristics	SOD-123

MAXIMUM RATING (@ $T_A = 25^\circ\text{C}$ unless otherwise specified)

Parameter	Symbol	Value	Unit
Forward Voltage @ $I_F=10\text{mA}$	V_F	0.9	V
Power Dissipation (Collector)	P_C	500	mW
Thermal Resistance (Junction-to-Ambient)	$R_{\theta JA}$	250	$^\circ\text{C}/\text{W}$
Thermal Resistance (Junction-to-Case)	$R_{\theta JC}$	140	$^\circ\text{C}/\text{W}$
Junction Temperature Range	T_J	-55 ~ +150	$^\circ\text{C}$
Storage Temperature Range	T_{STG}	-65 ~ +150	$^\circ\text{C}$

Note: These ratings are limiting values above which the serviceability of the diodes may be impaired.

SMT-Type Zener Diode

BZT52C2V0-BZT52C75

ELECTRICAL CHARACTERISTICS (@ T_A = 25°C unless otherwise specified)

Part Number	Marking Code	Zener Voltage V _Z (V)			@ I _{ZT} (mA)	Maximum Zener Impedance			Temperature Coefficient @ I _{ZT} T _C (mV/°C)		Maximum Reverse Current I _R (μA)	@ V _R (V)
		Min.	Typ.	Max.		Z _{ZT} (Ω) @ I _{ZT}	Z _{ZK} (Ω)	@ I _{ZK} (mA)	Min.	Max.		
BZT52C2V0	WY	1.90	2.00	2.10	5	100	600	1.0	-3.5	0.0	150.000	1.0
BZT52C2V2	22•	2.09	2.20	2.31	5	100	600	1.0	-3.5	0.0	150.000	1.0
BZT52C2V4	WX	2.28	2.40	2.52	5	100	600	1.0	-3.5	0.0	50.000	1.0
BZT52C2V7	W1	2.57	2.70	2.84	5	100	600	1.0	-3.5	0.0	20.000	1.0
BZT52C3V0	W2	2.85	3.00	3.15	5	95	600	1.0	-3.5	0.0	10.000	1.0
BZT52C3V3	W3	3.14	3.30	3.47	5	95	600	1.0	-3.5	0.0	5.000	1.0
BZT52C3V6	W4	3.42	3.60	3.78	5	90	600	1.0	-3.5	0.0	5.000	1.0
BZT52C3V9	W5	3.71	3.90	4.10	5	90	600	1.0	-3.5	0.0	3.000	1.0
BZT52C4V3	W6	4.09	4.30	4.52	5	90	600	1.0	-3.5	0.0	3.000	1.0
BZT52C4V7	W7	4.47	4.70	4.94	5	80	500	1.0	-3.5	0.0	3.000	2.0
BZT52C5V1	W8	4.85	5.10	5.36	5	60	480	1.0	-2.7	1.2	2.000	2.0
BZT52C5V6	W9	5.32	5.60	5.88	5	40	400	1.0	-2.0	2.5	1.000	2.0
BZT52C6V2	WA	5.89	6.20	6.51	5	10	150	1.0	0.4	3.7	3.000	4.0
BZT52C6V8	WB	6.46	6.80	7.14	5	15	80	1.0	1.2	4.5	2.000	4.0
BZT52C7V5	WC	7.13	7.50	7.88	5	15	80	1.0	2.5	5.3	1.000	5.0
BZT52C8V2	WD	7.79	8.20	8.61	5	15	80	1.0	3.2	6.2	0.700	5.0
BZT52C9V1	WE	8.65	9.10	9.56	5	15	100	1.0	3.8	7.0	0.500	6.0
BZT52C10	WF	9.50	10.00	10.50	5	20	150	1.0	4.5	8.0	0.200	7.0
BZT52C11	WG	10.45	11.00	11.55	5	20	150	1.0	5.4	9.0	0.100	8.0
BZT52C12	WH	11.40	12.00	12.60	5	25	150	1.0	6.0	10.0	0.100	8.0
BZT52C13	WI	12.35	13.00	13.65	5	30	170	1.0	7.0	11.0	0.100	8.0
BZT52C15	WJ	14.25	15.00	15.75	5	30	200	1.0	9.2	13.0	0.100	10.5
BZT52C16	WK	15.20	16.00	16.80	5	40	200	1.0	10.4	14.0	0.100	11.2
BZT52C18	WL	17.10	18.00	18.90	5	45	225	1.0	12.4	16.0	0.100	12.6
BZT52C20	WM	19.00	20.00	21.00	5	55	225	1.0	14.4	18.0	0.100	14.0
BZT52C22	WN	20.90	22.00	23.10	5	55	250	1.0	16.4	20.0	0.100	15.4
BZT52C24	WO	22.80	24.00	25.20	5	70	250	1.0	18.4	22.0	0.100	16.8
BZT52C27	WP	25.65	27.00	28.35	2	80	300	0.5	21.4	25.3	0.100	18.9
BZT52C30	WQ	28.50	30.00	31.50	2	80	300	0.5	24.4	29.4	0.100	21.0
BZT52C33	WR	31.35	33.00	34.65	2	80	325	0.5	27.4	33.4	0.100	23.1
BZT52C36	WS	34.20	36.00	37.80	2	90	350	0.5	30.4	37.4	0.100	25.2
BZT52C39	WT	37.05	39.00	40.95	2	130	350	0.5	33.4	41.2	0.100	27.3
BZT52C43	WU	40.85	43.00	45.15	2	100	700	1.0	10.0	12.0	0.100	32.0
BZT52C47	WV	44.65	47.00	49.35	2	100	750	1.0	10.0	12.0	0.100	35.0
BZT52C51	WW	48.45	51.00	53.55	2	100	750	1.0	10.0	12.0	0.100	38.0
BZT52C56	WX•	53.20	56.00	58.80	2	200	400	0.5	10.0	12.0	0.045	39.2
BZT52C62	6E	58.90	62.00	65.10	2	215	423	0.5	10.0	12.0	0.045	43.4
BZT52C68	6F	64.60	68.00	71.40	2	240	447	0.5	10.0	12.0	0.045	47.6
BZT52C75	6H	71.25	75.00	78.75	2	255	470	0.5	10.0	12.0	0.045	52.5

SMT-Type Zener Diode

BZT52C2V0-BZT52C75

TYPICAL CHARACTERISTICS (@ $T_A = 25^\circ\text{C}$ unless otherwise specified)

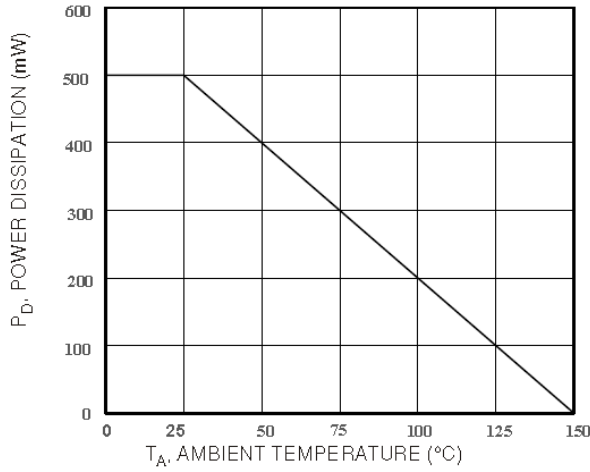

Fig. 1 Power Derating Curve

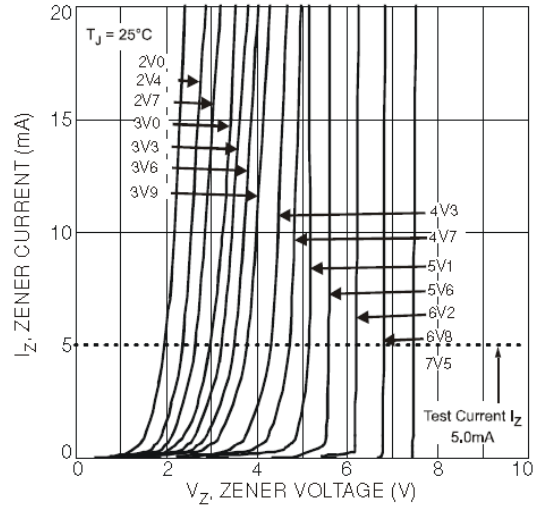

Fig. 2 Typical Zener Breakdown Characteristics

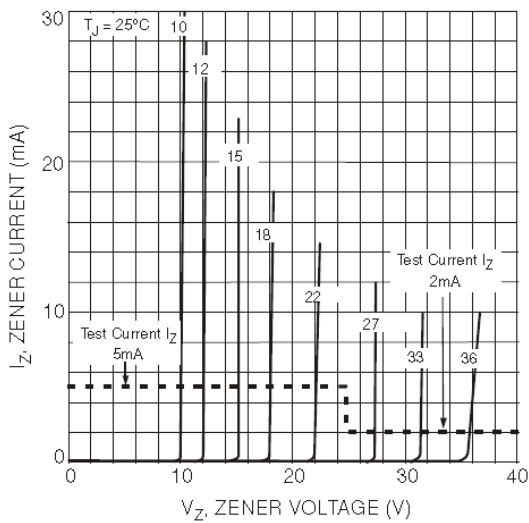

Fig. 3 Typical Zener Breakdown Characteristics

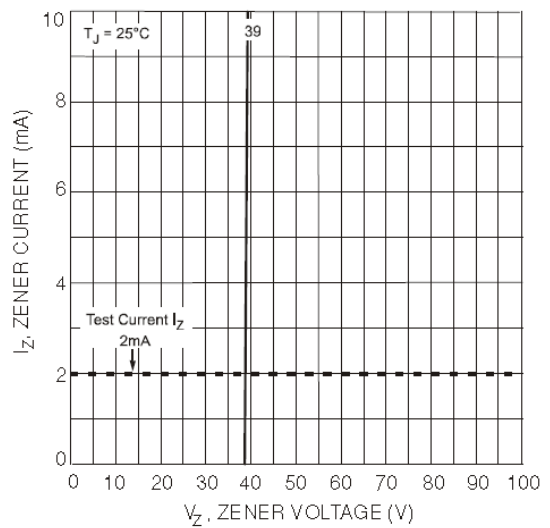

Fig. 4 Typical Zener Breakdown Characteristics

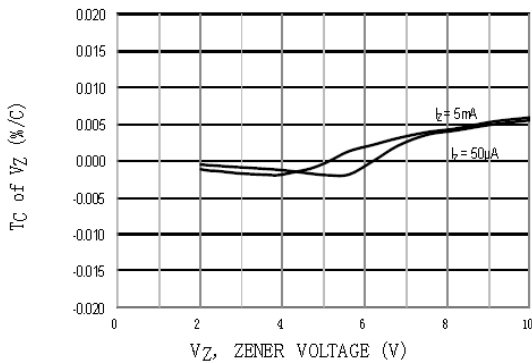

Fig. 5 Typical Temperature Coefficient of Zener Voltage

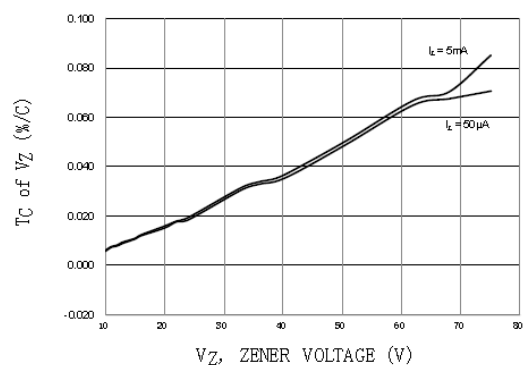

Fig. 6 Typical Temperature Coefficient of Zener Voltage

SMT-Type Zener Diode

BZT52C2V0-BZT52C75

PACKAGE OUTLINE (Unit: mm)

Plastic surface mounted package

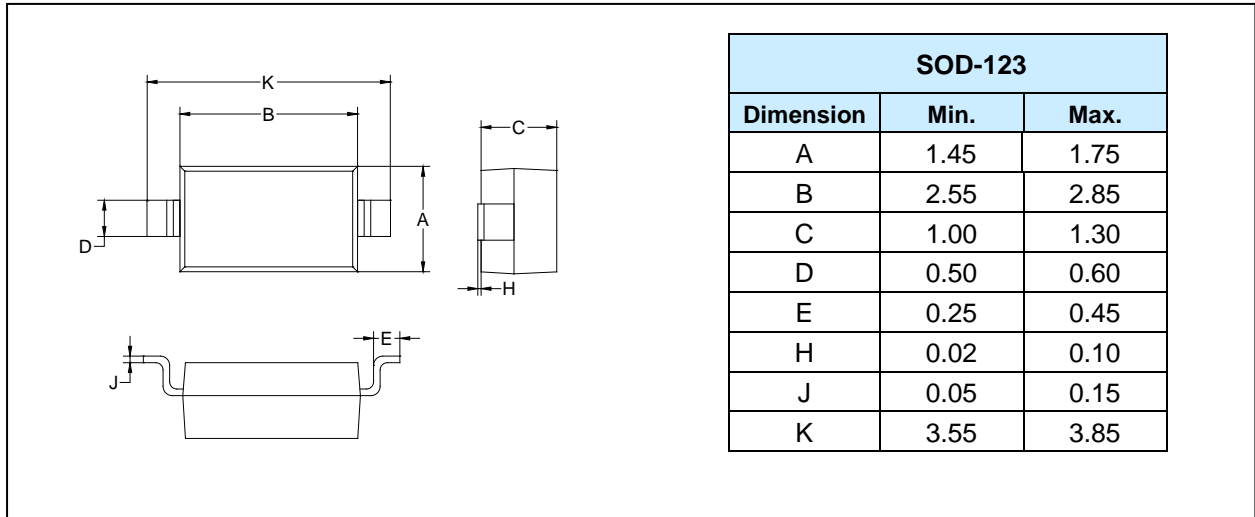

MOUNTING PAD LAYOUT (Unit: mm)

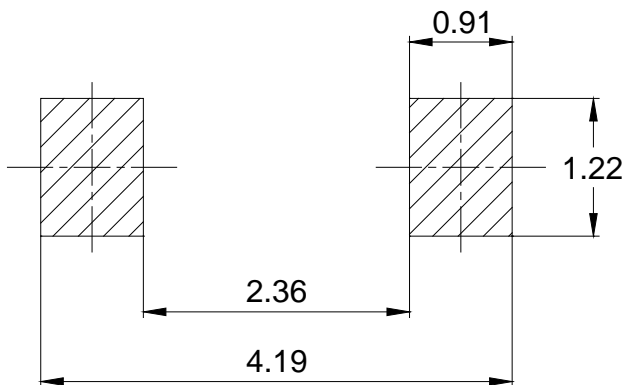

PACKAGE INFORMATION

Part Number	Package	Shipping Quantity
BZT52C2V0 - BZT52C75	SOD-123	3000pcs / Tape & Reel

SMT-Type Zener Diode

BZT52C2V0-BZT52C75

IMPORTANT NOTICE

Changzhou Galaxy Century Microelectronics (GME) reserves the right to make changes without further notice to any product information (copyrighted) herein to make corrections, modifications, improvements, or other changes. GME does not assume any liability arising out of the application or use of any product described herein; neither does it convey any license under its patent rights, nor the rights of others.