

### Features

- High current rectifier schottky diode
- Low voltage
- Low inductance
- For power supply

HF

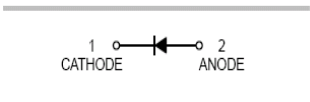

1 CATHODE 2 ANODE

### Application

- High frequency rectification

### Mechanical Data

- Case: SOD-323
- Molding Compound: UL Flammability Classification Rating 94V-0
- Terminals: Matte tin-plated leads; solderability-per MIL-STD-202, Method 208



RB551V-30  
SOD-323

### Ordering Information

Part Number	Package	Shipping Quantity	Marking Code
RB551V-30	SOD-323	3000pcs / Tape & Reel	D

### Maximum Ratings (@ T<sub>A</sub> = 25°C unless otherwise specified)

Parameter	Symbol	Value	Unit
Peak Repetitive Reverse Voltage	V <sub>RRM</sub>	30	V
DC Reverse Voltage	V <sub>R</sub>	20	V
Maximum Average Forward Output Current	I <sub>F(AV)</sub>	0.5	A
Peak Forward Surge Current (8.3ms single half sine-wave)	I <sub>FSM</sub>	2	A

### Thermal Characteristics

Parameter	Symbol	Value	Unit
Thermal Resistance Junction-to-Air **1	R <sub>θJA</sub>	500	°C/W
Operating junction Temperature	T <sub>J</sub>	100	°C
Storage Temperature Range	T <sub>STG</sub>	-40 ~ +125	°C

**Electrical Characteristics** (@  $T_A = 25^\circ\text{C}$  unless otherwise specified)

Parameter	Symbol	Test Condition	Min.	Typ.	Max.	Unit
Forward Voltage <sup>*2</sup>	$V_F$	$I_F = 100\text{mA}$	-	-	0.36	V
		$I_F = 500\text{mA}$	-	-	0.47	V
Maximum Peak Reverse Current	$I_R$	$V_R = 20\text{V}$	-	-	100	$\mu\text{A}$
Typical Junction Capacitance	$C_J$	$V_R = 0\text{V}, f = 1\text{MHz}$	-	-	120	pF

Notes:

1. Part mounted on FR-4 board with recommended pad layout
2. Pulse width  $\leq 380\mu\text{s}$ , Duty cycle  $< 2\%$

Ratings and Characteristic Curves (@  $T_A = 25^\circ\text{C}$  unless otherwise specified)

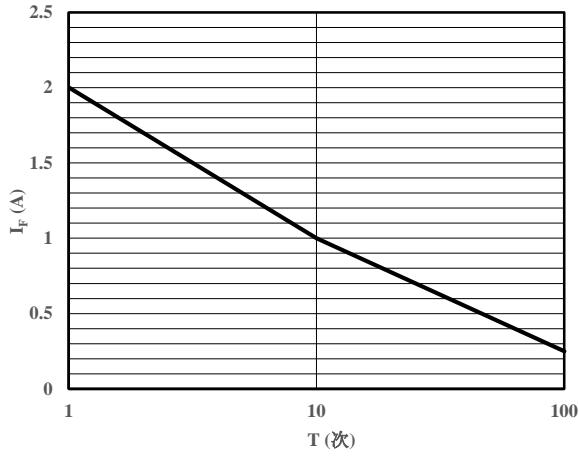

Fig 1 Peak Forward Surge Current

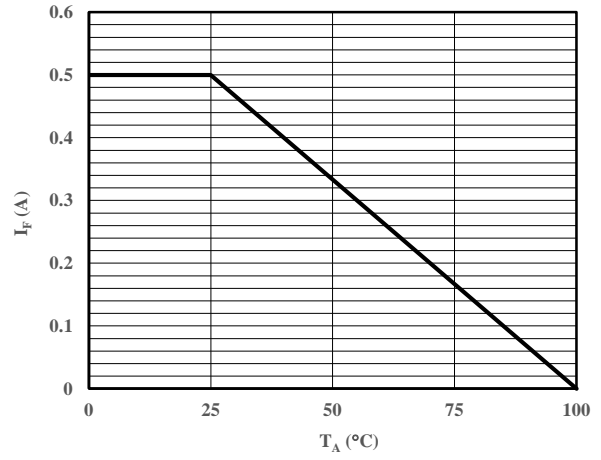

Fig 2 Current Derating Curve

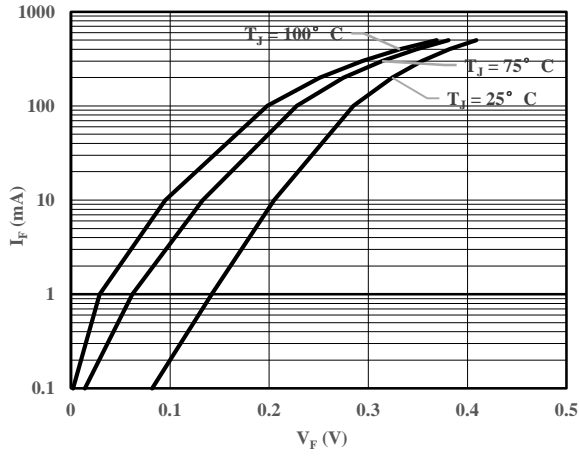

Fig 3 Typical Forward Characteristic

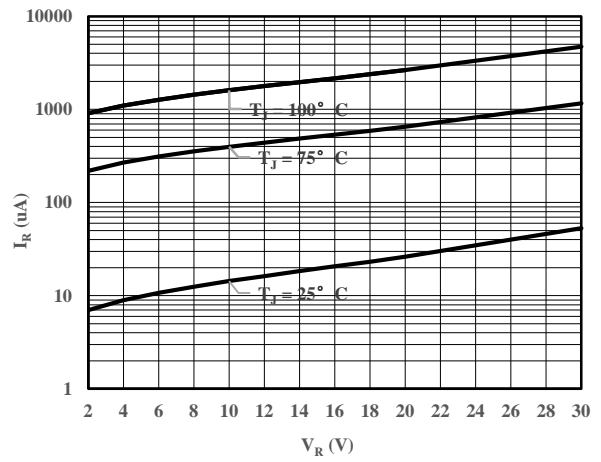

Fig 4 Typical Reverse Characteristic

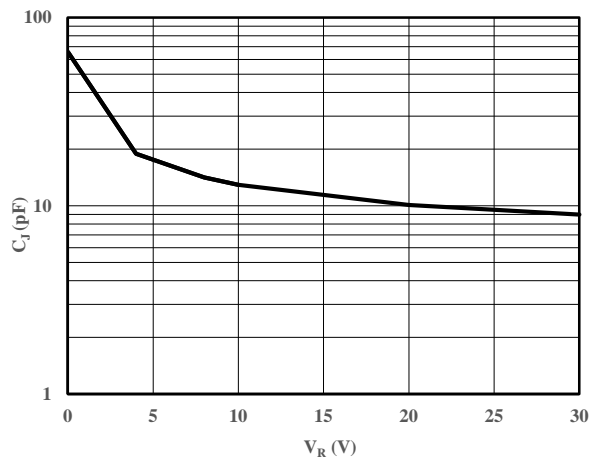
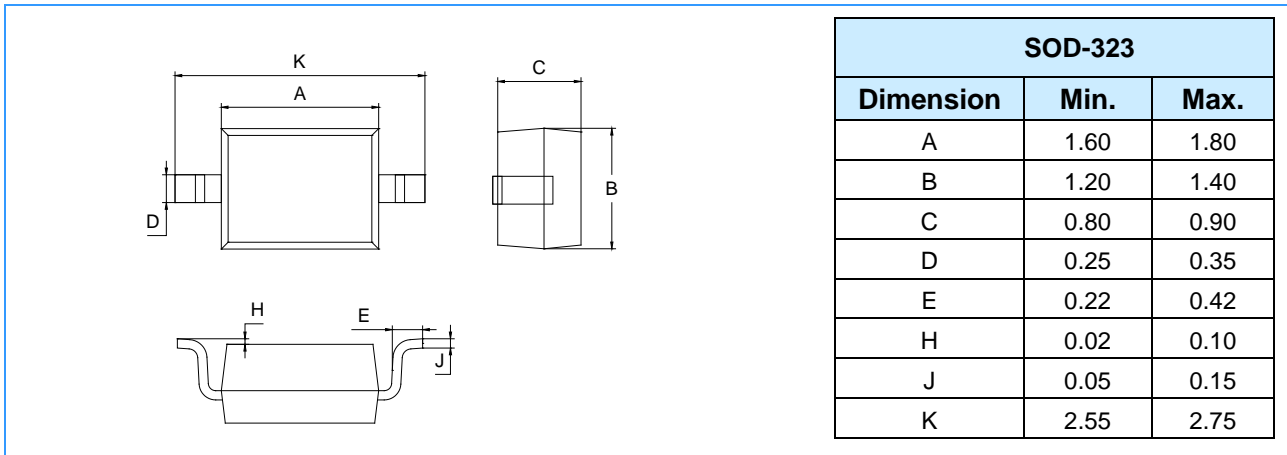
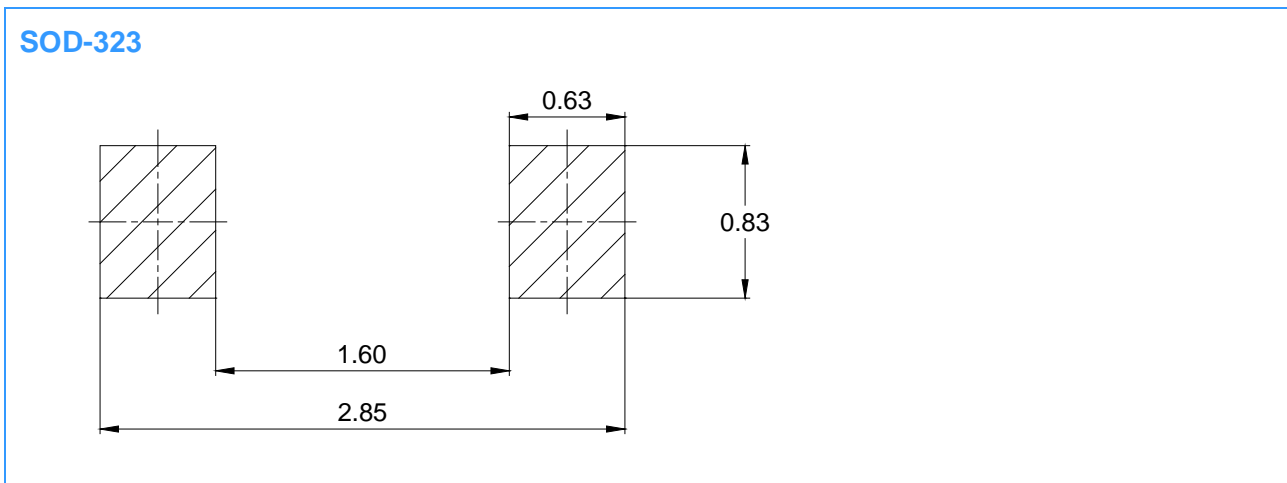

Fig 5 Typical Junction Capacitance

Package Outline Dimensions (Unit: mm)



Mounting Pad Layout (Unit: mm)



Important Notice

Changzhou Galaxy Century Microelectronics (GME) reserves the right to make changes without further notice to any product information (copyrighted) herein to make corrections, modifications, improvements, or other changes. GME does not assume any liability arising out of the application or use of any product described herein; neither does it convey any license under its patent rights, nor the rights of others.